



New Doosan Warehouse Equipment

Elektric Pallet Truck

LEDH 40 + LEDH 50

LOAD CAPACITY 4,000 kg or 5000kg

Design features

- Powerfull and economical per AC controlled drive contactorless electronics
- Strong drive motor for a optimal traction
- Robust, stabil 5-point chassis with small truck dimension

Operating Elements

- Multifunctional, ergonomical handles
- Controller for smooth ones drive forward and backwards

Standard Equipment

- Drive wheel Vulkollan
- Load wheels Vulkollan

Options

- Various fork length
- Battery 24v 4 EPzS up to 360 Ah

Made in Germany



Technical Spezifikation

Manufacturer's type designation			LEDH 40	LEDH 50
Load capacity	Q	kg	4000	5000
Load centre distance	c	mm	600	600
Height, lowered	h13	mm	90	95
lifting height	h3	mm	215	215
Height of Tiller in drive position	h14	mm	1350	1350
Overall length	L	mm	1945	1945
Overall width	B	mm	690	690
Length to face of forkes	l2	mm	755	755
wheel base	y	mm	1445	1445
Load Wheel position	RTA	mm	865	865
Fork length	l	mm	1190	1190
Fork width	e	mm	200	200
Distance over fork-arms	b5	mm	580	580
Turning radius	RWa	mm	1630	1630
Weight (without battery)	m	kg	600	600
Aisle width for pallets, 800x1200 mm,along	Ast	mm	2170	2170
Battery Capacity		Ah	160-320	160-320
Battery voltage / nominal capacity		V	24	24
Battery acc. to DIN 43535 A / B / C / no	24V4EPzS	160..320Ah	.	.
AC - Drive motor	n/V/kW		1/24/2,0	1/24/2,0
drive steering	Impuls		AC	AC
DC - Lift motor	n/V/kW		1/24/2,2	1/24/2,2

technical modifications are subject to alteration without notice

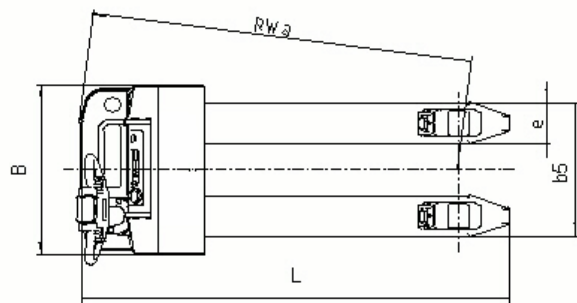
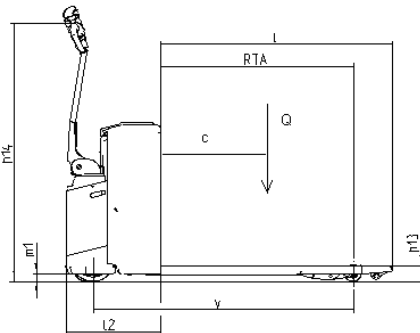

Europien Office: Europark Noord 36 B-9100 Sint Niklaas
 Tel: +3237600987
 Fax: +3237600989
 Web site: www.doosaneurope.com

