

MAST SPECIFICATIONS and RATED CAPACITIES

BC20S-7 & BC25S-7

Mast Type	Maximum Fork Height	Fully Lowered Height	Fully Extended Height	Free Lift	Rated Load Capacities								
					BC20S-7			BC25S-7					
					With Load Backrest	With Load Backrest	With Load Backrest	Tilt Angle		Load Capacities	Tilt Angle		Load Capacities
								FWD	BWD		FWD	BWD	
mm	mm	mm	mm	deg	deg	kg	deg	deg	kg				
STD	2580	1790	3830	147	6	10	2000	6	10	2500			
	2950	1975	4200	147	6	10	2000	6	10	2500			
	3230	2115	4480	147	6	10	2000	6	10	2500			
	3500	2365	4755	147	6	8	2000	6	8	2500			
	3800	2515	5055	147	6	8	2000	6	8	2500			
	3950	2590	5205	147	6	8	2000	6	8	2500			
	4350	2790	5605	147	6	8	2000	6	8	2425			
	4960	3090	6205	147	6	8	1925	6	8	2300			
FF	2580	1790	3830	585	6	8	2000	6	8	2500			
	2950	1975	4200	770	6	5	2000	6	5	2500			
	3230	2115	4480	910	6	5	2000	6	5	2500			
	3600	2365	4855	1160	6	5	2000	6	5	2500			
FFT	3900	1815	5155	610	6	5	2000	6	5	2500			
	4290	1950	5560	745	6	5	2000	6	5	2425			
	4730	2090	5980	885	6	5	2000	6	5	2325			
	5560	2440	6805	1235	6	5	1825	6	5	2175			
	6010	2590	7255	1385	6	5	1750	6	3	2075			

BC30S-7

Mast Type	Maximum Fork Height	Fully Lowered Height	Fully Extended Height	Free Lift	Rated Load Capacities					
					BC30S-7					
					With Load Backrest	With Load Backrest	With Load Backrest	Tilt Angle		Load Capacities
								FWD	BWD	
mm	mm	mm	mm	deg	deg	kg				
STD	2030	1515	3280	152	6	10	3000			
	2580	1790	3830	152	6	10	3000			
	2950	1975	4200	152	6	10	3000			
	3230	2115	4480	152	6	10	3000			
	3500	2365	4755	152	6	8	3000			
	3800	2515	5055	152	6	8	3000			
	3950	2590	5205	152	6	8	3000			
	4350	2790	5605	152	6	8	3000			
	4960	3090	6205	152	6	5	2850			
	FF	2580	1790	3830	590	6	8	3000		
2950		1975	4200	775	6	5	3000			
3230		2115	4480	915	6	5	3000			
3600		2365	4855	1165	6	5	3000			
FFT	3900	1840	5155	640	6	5	2900			
	4290	1975	5560	775	6	5	2900			
	4730	2115	5980	915	6	5	2900			
	5560	2465	6805	1265	6	5	2700			
	6010	2615	7255	1415	6	3	2475			



7-Series Forklifts Cushion Electric 2.0 to 3.0 ton Capacity

BC20S/BC25S/BC30S-7



Doosan Industrial Vehicles UK Limited

12 Brackmills Industrial Estate
Kilvey Road
Northampton
NN4 7BQ

Tel.: 01604 825 600
Website: www.doosanift.com

AUTHORIZED DEALER

Lifting Your Dreams

GENERAL SPECIFICATION

Characteristics	1.1	Manufacturer			DOOSAN
	1.2	Model			BC20S-7
	1.3	Drive			Electric
	1.4	Operator type			Seated
	1.5	Load capacity	Q	kg	2000
	1.6	Load center	c	mm	500
	1.8	Load distance (LMC)	x	mm	405
	1.9	Wheelbase	y	mm	1280
	Weights	2.1	Service weight (with min. weight of battery)		kg
2.2		Axle loading, loaded front/rear		kg	5584/585
2.3		Axle loading, unloaded front/rear		kg	1998/2171
Wheels & Tires	3.1	Tires: pneumatic (P), superelastic (SE), cushion (C)			C
	3.2	Tire size, front			21x7x15
	3.3	Tire size, rear			16x6x10.5
	3.5	Wheels, number front/rear (x=driven wheels)			2x/2
	3.6	Tread width, front	b10	mm	932
	3.7	Tread width, rear	b11	mm	902
	Basic dimensions	4.1	Tilt of mast forward / backward	α / β	deg
4.2		Height, mast lowered	h1	mm	2115
4.3		Free lift	h2	mm	152
4.4		Lift (with STD 2-stage mast)	h3	mm	3230
4.5		Height, mast extended	h4	mm	4480
4.7		Height to top of overhead guard	h6	mm	2210
4.8		Seat height/stand height	h7	mm	1115
4.12		Towing coupling height	h10	mm	300
4.19		Overall length	l1	mm	3155
4.20		Length to face of forks	l2	mm	2105
4.21		Overall width	b1	mm	1110
4.22		Fork dimensions	s / e / l	mm	40x100x1050
4.23		Fork carriage ISO 2328. Class/type A, B			2A
4.24		Fork carriage width		mm	973
4.24a		Fork Spacing (min/max)		mm	297/905
4.31		Ground clearance	m1	mm	80
4.32		Ground clearance, centre of wheelbase	m2	mm	103
4.34.1		Aisle width for pallets 1000 x 1200 crossways	Ast	mm	3465
4.34.1		Aisle width for pallets 800 x 1200 lengthways	Ast	mm	3665
4.35	External turning radius	Wa	mm	1860	
4.36	Internal turning radius		mm	585	
Performance	5.1	Travel speed, loaded / unloaded		km/h	18.0/18.0
	5.2	Lift speed, loaded / unloaded		mm/s	460/640
	5.3	Lowering speed, loaded / unloaded		mm/s	500/460
	5.6	Maximum drawbar pull		N	14216
	5.8	Maximum gradeability		%	24
Electric	5.1	Service brake			Hydraulic
		Parking brake			Auto-Electric
	6.1	Drive motor rating S2 60 minute		kW	16
	6.2	Lifting motor rating at S3 15%		kW	18
	6.3	Battery type			Lead-acid
Electric	6.3a	Battery Compartment (length x width x height)	Nominal	mm	1017x776x610
	6.4	Battery voltage/nominal (max.) capacity K5		V/Ah	48 / 735
	6.5	Battery weight (min/max)		kg	1040 / 1430
Others	8.1	Type of drive control unit			AC
	10.1	Operating pressure for systems / attachments	System	kPa	16600
			Attachment	kPa	15500
10.7	Sound level at the driver's ear according to EN 12 053			dB (A)	69

DOOSAN	DOOSAN
BC25S-7	BC30S-7
Electric	Electric
Seated	Seated
2500	3000
500	500
405	406
1280	1380
4739	4995
6493/746	7177/817
2010/2728	1971/3024
C	C
21x7x15	21x8x15
16x6x10.5	16x6x10.5
2x/2	2x/2
932	907
902	902
6 / 10	6 / 10
2115	2115
152	152
3230	3230
4480	4480
2210	2210
1115	1115
300	300
3172	3290
2122	2240
1110	1110
40x100x1050	45x125x1050
2A	3A
973	1025
297/905	282/954
80	80
103	103
3468	3578
3668	3778
1863	1972
585	595
18.0/18.0	18.0/18.0
400/640	350/630
500/460	500/460
14216	14216
21	18
Hydraulic	Hydraulic
Auto-Electric	Auto-Electric
16	16
18	18
Lead-acid	Lead-acid
1017x776x610	1017x876x610
48 / 735	48 / 840
1270 / 1430	1360 / 1755
AC	AC
19300	21100
15500	15500
69	69

DIMENSIONAL DRAWING

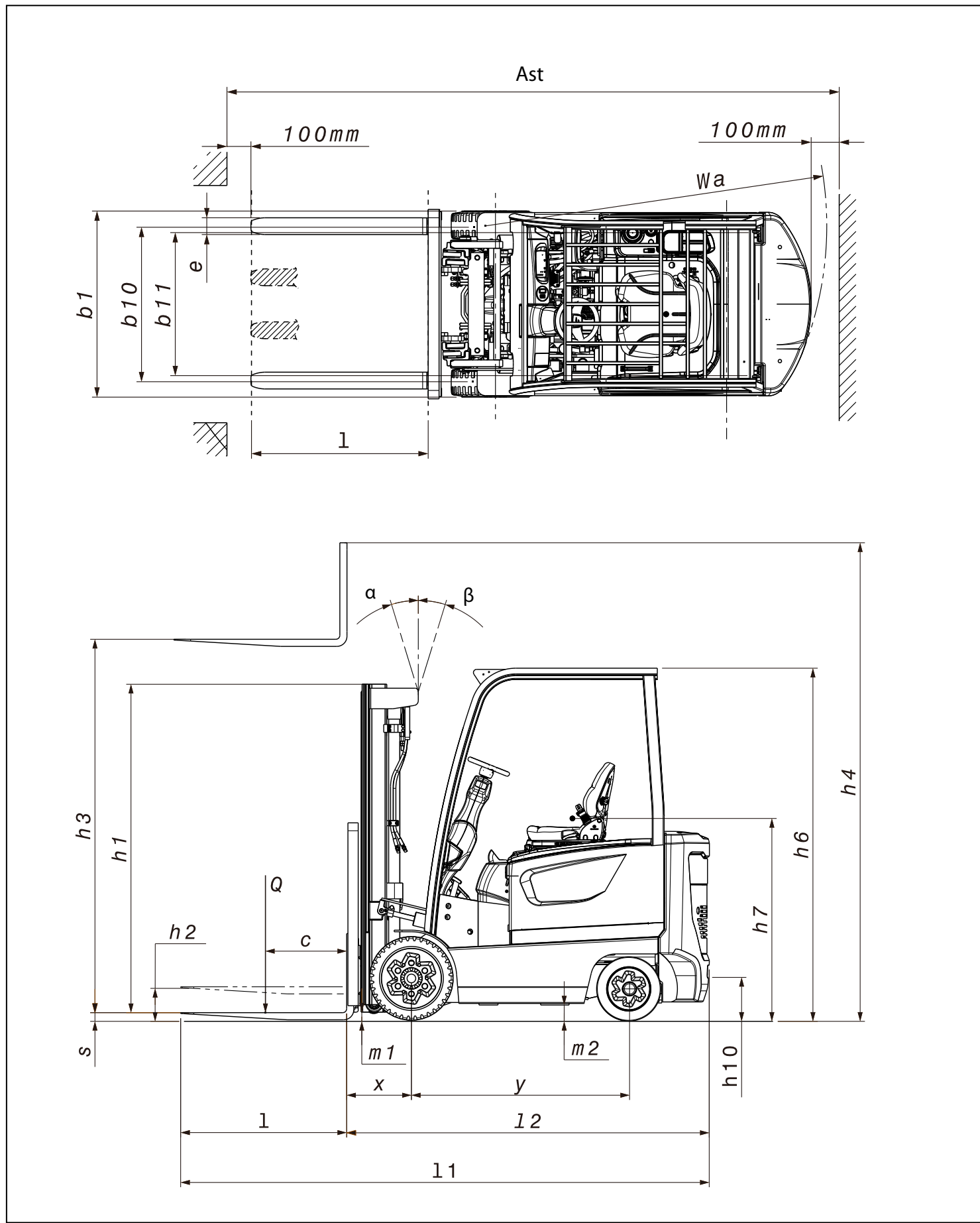

Note: Specification values quoted in this specification sheet have been rounded. Performance may vary due to operation conditions. Products and specifications are subject to improvement and change without prior notices.